

## TONDO PER CEMENTO ARMATO

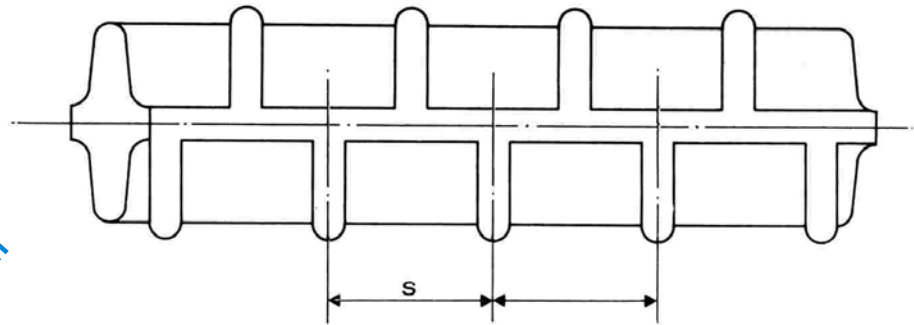
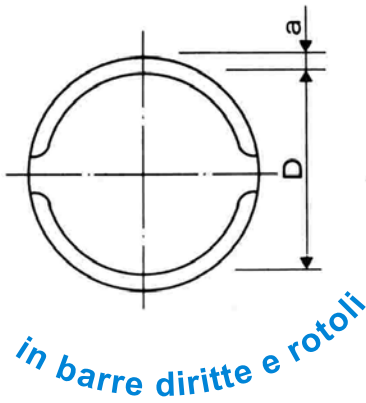

tensioni ammissibili (kgf/mm<sup>2</sup>)

Fe B 32 K	= 1600	Fe B 44 K (non controllato)	= 2200
Fe B 38 K (non controllato)	= 1900	Fe B 44 K (controllato)	= 2600

Diametro nominale mm	Peso Kg/m	Sezione cm <sup>2</sup>	Diametro del mandrino da usarsi per gli uncini di ancoraggio D. M. 26 MAR 80 G. U. n° 176 - 28 GIU 80		
			Fe B 32 K	Fe B 38 K	Fe B 44 K
5	0.154	0.20	25	30	30
6	0.222	0.28	30	36	36
7	0.302	0.38	35	42	42
8	0.395	0.50	40	48	48
9	0.499	0.64	45	54	54
10	0.617	0.79	50	60	60
11	0.746	0.95	55	66	66
12	0.888	1.13	60	72	72
14	1.208	1.54	70	84	84
16	1.578	2.01	80	96	96
18	1.998	2.54	90	108	108
20	2.466	3.14	100	120	120
22	2.984	3.80	110	132	132
24	3.551	4.52	120	144	144
26	4.168	5.31	130	156	156
28	4.834	6.16	140	168	168
30	5.549	7.07	150	180	180
32	6.310	8.04	160	192	192
36			180	216	216
40			200	240	240